



SECATOL

LARGE CAPACITY AUTOVID PAL C



The Autovid PAL C Boat Skip is designed for handling rubble, earth and other materials around a construction site. The skip is fitted with a hinged reinforced bale arm which, with the skip sitting on the ground, hinges to the rear and this coupled with its low profile enables easy loading.

When discharging, the vertical position of the skip along with its design ensures a quick and complete operation. The skip can be used by the crane operator without the need for an assistant. The cycle of operation is very simple as the crane operator only has to lift and lower the crane hook.

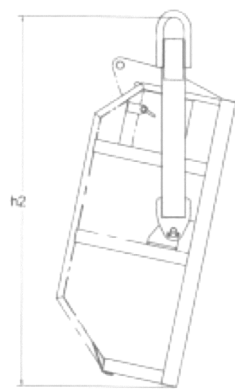
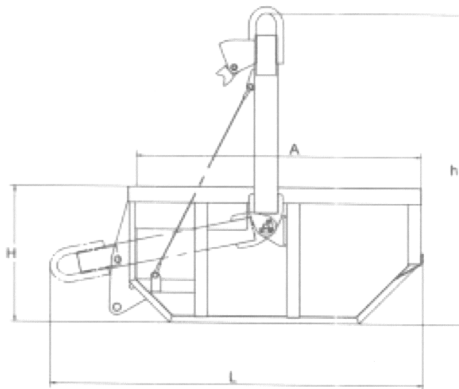
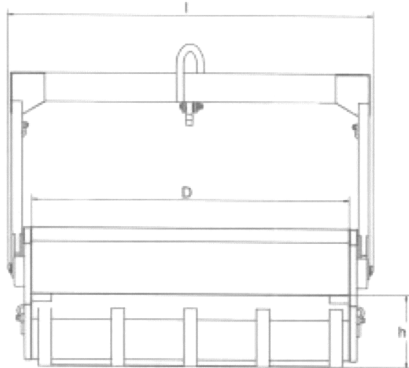

Capacity in litres	Dimensions in mm								Unladen weight (Kg)
	A	D	h	h1	h2	Length	width	Height	
4000	2490	1400	760	2787	3115	3212	1825	1560	1450
5000	2490	1700	760	2852	3220	3332	2115	1560	1638
6000	2490	2000	760	2882	3250	3362	2415	1560	1720
8000	3000	2350	760	3084	3700	3810	2790	1560	2260

WHITNEY ENGINEERING LIMITED

Unit 6, Ladford Trading Park, Seighford, Stafford, ST18 9QE

Tel: 01785 282811 Fax: 01785 282930

Email: sales@whitneyeng.co.uk Web: www.whitneyeng.co.uk