



AUTOVID PB SELF-DISCHARGE SKIP



The Autovid PB Boat Skip is designed for handling rubble, earth and other materials around a construction site. The skip is fitted with a hinged reinforced bale arm which offers three advantages over traditional circular tipping skips.

1. With the skip sitting on the ground the bale arm hinges to the rear and this, coupled with its low profile, enables easy loading.
2. When discharging, the design along with the vertical position of the skip ensures fast and complete emptying.
3. The skip can be used by the crane operator without the need for an assistant. The cycle of operation is very simple as the crane operator only has to lift and lower the hook.

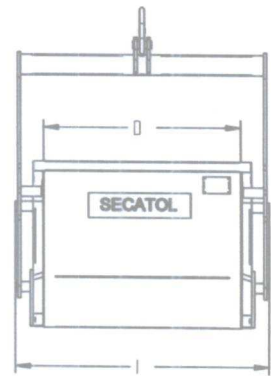
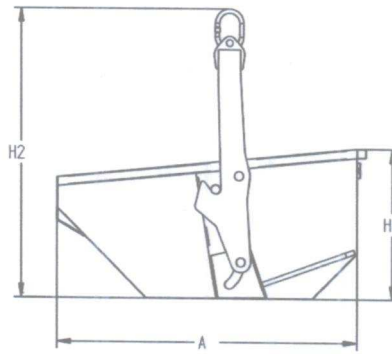
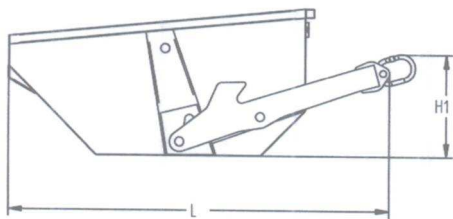
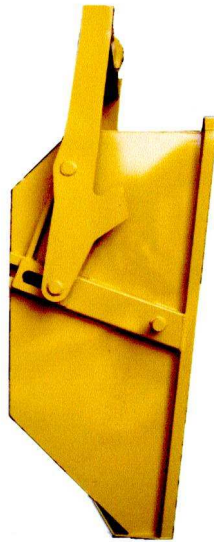

Capacity in litres	Dimensions in mm								Unladen weight (Kg)
	A	D	H	h1	h2	Length	Width	Height	
500	1350	800	667	465	1290	1735	1030	667	158
1000	1705	1000	844	819	1650	2272	1280	844	290
1500	2000	1110	1003	658	1693	2700	1366	1003	385
2000	2260	1200	1050	590	1950	2900	1540	1050	502

WHITNEY ENGINEERING LIMITED

Unit 6, Ladford Trading Park, Seighford, Stafford, ST18 9QE

Tel: 01785 282811 Fax: 01785 282930

Email: sales@whitneyeng.co.uk Web: www.whitneyeng.co.uk