

TELESCOPIC BRICK FORK

Self-leveling device

WHITNEY

SECATOL



The GER AU RH Telescopic Brick Forks are designed to lift both brick packs and pallets, by utilising the adjustable forks and three position load height setting.

The compensation mechanism attached to the lifting eye ensures the forks remain level with or without a load.

The GER AU RH is supplied with a safety net to comply with current regulations, is CE marked with EC Declaration of Conformity and Test Certificate.

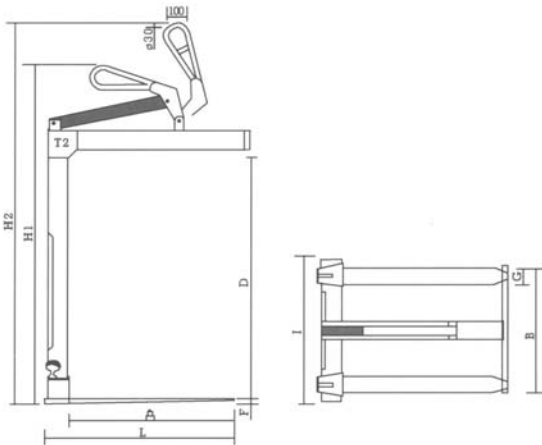

Height position	Dimensions in mm									Unladen weight (Kg)
	A	B	D	F	G	H1	H2	I	L	
1			1570			2155	2510			
2	1110	450-850	1700	50	80	2390	2745	920	1260	240
3			1830			2625	2980			

WHITNEY

Ladybird House, Brockhill Yard, Hewell Lane, Redditch, B97 6QT
www.whitneyeng.com sales@whitneyeng.com 01785 282811
 Sole UK dealers for SECATOL Equipment

GER AU RH