

# BOTTLE RACK

**WHITNEY****SECATOL**

**Presentation:** Two lateral fork pockets allow the bottle rack to be lifted by a forklift. An upper hook has been designed to enable the lifting through cranes, tackles or overhead cranes on forklift. The bottles are held by semi-circle and removable rigid bars.

**Use:** Handling, transport and storing in all safety of bottles of gas, pressurized air or other, of a diameter inferior to 250 mm.

### 3 versions:

- **POB 2** : for 2 bottles Ø 250 mm
- **POB 4** : for 4 bottles Ø 250 mm
- **POB 2 + 2** : for 2 bottles Ø 230 mm + 2 bottles Ø 400 mm

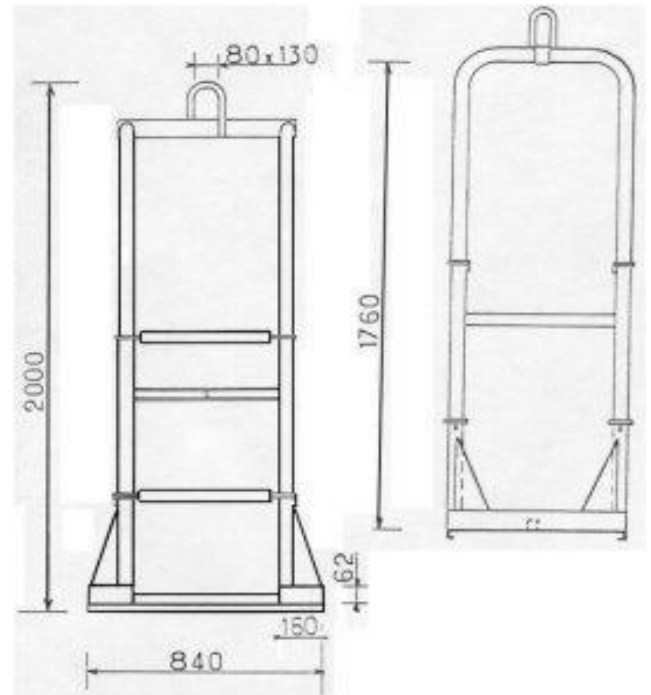
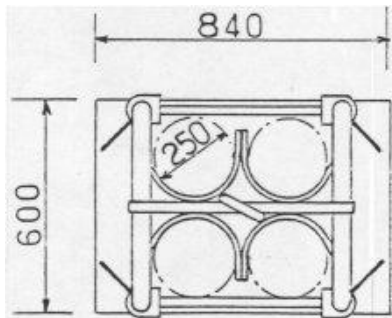

Product code	Reference	Number of bottles	Weight (in Kg)
61002	POB 2	2	60
61004	POB 4	4	80
61005	POB 2 + 2	4	85

These technical details are given for information purposes only. they can be changed without any notice.

**WHITNEY**

Ladybird House, Brockhill Yard, Hewell Lane, Redditch, B97 6QT  
www.whitneyeng.com sales@whitneyeng.com 01785 282811  
Sole UK dealers for SECATOL Equipment

POB 2  
POB 4  
POB 2+2